

# MF920U

## Quick Start Guide





# Getting to Know Your Device

---

## Appearance

The following figure is for your reference only.

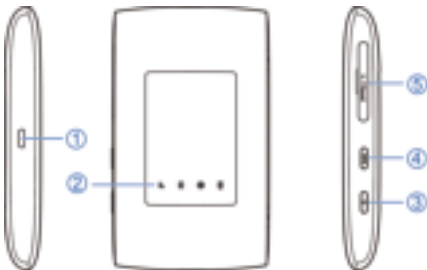

1. Charging/micro-USB jack
2. Indicator light
3. Power key
  - Press and hold for about 2 seconds to power on/off your device.
  - Press and hold for about 10 seconds to power off your device, if it is in abnormal status. And then press and hold for about 2 seconds to power on your device again.

#### 4. WPS key

Press and hold for about 2 seconds to activate the WPS function.



#### 5. micro-SIM card slot and reset hole



Reset hole: Press and hold for about 2 seconds to restore your device to the factory settings.

## Getting to Know Your Device

---

### Indicator lights

Indicator	Status	Description
Battery 	Red solid / blinking	The battery is low. Please charge the battery.
	Green blinking	The battery is being charged.
	Green solid	The battery level is middle or high.
	Light off	Your device is powered off and not being charged.
Wi-Fi 	Blue solid	Wi-Fi is active.
	Blue blinking	WPS is active.
	Light off	Wi-Fi is off.

SMS 	Blue solid	You have unread messages.
	Blue blinking	You have new messages or the message storage is full.
	Light off	There is neither an unread message nor a new message.
Network 	Red	The device is in error status. <ul style="list-style-type: none"> <li>• The device is not registered to the mobile network.</li> <li>• There is no micro-SIM card inserted.</li> <li>• There is no network service available.</li> </ul>
	Green solid	The device is registered to the 2G/3G mobile network.
	Green blinking	The device is connected to the 2G/3G mobile network and data is being transferred.
	Blue solid	The device is registered to the 4G LTE network.
	Blue blinking	The device is connected to the 4G LTE network and data is being transferred.

## Getting to Know Your Device

---

### Connection Scenarios

The device uses your micro-SIM card to access the Internet. It allows multiple clients to surf on the Internet at the same time. The following figure is for your reference only.



## Installing the micro-SIM Card

---

1. Open the micro-SIM card slot cover.

 **NOTE:**

Do not remove the cover rudely, because it is connected with the device.



2. Install a micro-SIM card to the micro-SIM card slot.

 **WARNING!**

Your device does not support SIM cards, nano-SIM cards or any other non-standard micro-SIM cards. To avoid damage to the device, do not use those cards or any card holders.



3. Close the micro-SIM card slot cover.

# Connecting to Your Device

---

## Using Wi-Fi

1. Power on your device.
2. Ensure that your computer or other client devices have enabled Wi-Fi, and search for available wireless networks.

 **NOTE:**

Refer to your Wi-Fi-enabled client device manual for further details on how to search for wireless networks. If you use a computer, you need to set your computer to obtain an IP address automatically.

3. Select the Wi-Fi name (SSID) of your device, and click **Connect**.
4. Enter the Wi-Fi password if necessary, and click **OK**.

 **NOTE:**

Refer to the chapter *Getting to Know the Wi-Fi SSID and Password* to get the default Wi-Fi SSID and password.

5. Wait until the client device is connected to your device successfully.



## Using a USB Cable

1. Connect a computer to your device with a USB cable.
2. Power on your device. The operating system detects and identifies new hardware, and automatically installs the software.

### **NOTE:**

If the system does not automatically launch installation, you can double-click the device installation icon in **My Computer > ZTEMODEM** to install the software.

3. Wait until the computer is connected to your device successfully.

## Getting to Know the Wi-Fi SSID and Password

---

You can view the label on the device to get the default Wi-Fi SSID and password.

## Logging in to the 4G Mobile Hotspot Configuration Page

---

1. Ensure that the connection between your device and the client device is correct.
2. Launch the Internet browser and enter **http://192.168.0.1** or **http://ufi.ztedevice.com** in the address bar.
3. Enter the password to log in to the 4G Mobile Hotspot configuration page.



### NOTE:

You can view the label on the device to get the default password.

## Changing the Wi-Fi SSID or Password



---

1. Log in to the 4G Mobile Hotspot configuration page.
2. Select Wi-Fi **Settings**.
3. Change the **Network Name (SSID)** or the **Password** in the Main SSID area.
4. Click **Apply**.

## Accessing the Internet

---

After a client device is successfully connected to your device, you can access the Internet in **Automatic** or **Manual** mode. The default mode is **Automatic**.

Mode	Operation
Automatic	Your device is automatically connected to the Internet, and you can surf on the Internet through the client.
Manual	Log in to the 4G Mobile Hotspot configuration page. Select network <b>Settings &gt; Connection Mode &gt; Manual</b> , and then click <b>Apply</b> . Click  to return to the home page, and then click  or  .

### **NOTE:**

- To change the current connection setting, please disconnect from the Internet first.
- To modify the parameters of your device, log in to the 4G Mobile Hotspot configuration page.

## Configuring Your PC

---

The following procedure describes how to configure the Internet Protocol in Windows for your Wi-Fi connection.

1. Right-click **Network** and select **Properties**.
2. Select **Change adapter settings**.
3. Right-click **Wireless Network Connection** and select **Properties**.
4. Select **Internet Protocol Version 4 (TCP/IPv4)**, and click **Properties**.
5. Select **Obtain an IP address automatically** and **Obtain DNS server address automatically**, and click **OK**.

## Warning and Notice

---

### To the Users

- If inadequately shielded, some electronic devices, for example, the electronic system of vehicles, may be affected by the electromagnetic interference caused by the device. Consult the manufacturers of such devices before using the device if necessary.

- Operating the device may interfere with medical instruments such as hearing aids and pacemakers. Always keep the device more than 20 centimeters away from such medical instruments when your device is powered on. Power off the device if necessary. Consult a physician or the manufacturers of medical instruments before using the device if necessary.
- Be aware of the usage limitation when using the device at places such as oil warehouses or chemical factories, where there are explosive gases or explosive products being processed. Power off the device if necessary.
- Do not use electronic transmission devices in aircraft, at petrol stations or in hospitals. Observe and obey all warning signs, and power off the device in these conditions.
- Do not touch the inner antenna area unless necessary. Otherwise the performance of the device may be affected.
- Do not use the device in an enclosed environment or where heat dissipation is poor. Prolonged work in such space may cause excessive heat and raise ambient temperature, which may lead to automatic shutdown of the device for your safety. In the case of such an event, cool the device in a well-ventilated place before turning on for normal use.

- Keep the device out of the reach of small children. The device may cause an injury if used as a toy.
- When the device is operating, do not touch the metallic parts. Failing to do so may cause burns.
- Use original accessories or accessories that are authorized. Using any unauthorized accessories may affect the performance of the device and violate the related national regulations about telecom terminals.
- Avoid using the device near or inside metallic constructions or establishments that can emit electromagnetic waves, because signal reception may be affected.
- The device is not waterproof. Keep the device dry and store it in a shady and cool place.
- Do not use the device immediately after a sudden temperature change, because dew may be generated inside and outside the device. Do not use it until it becomes dry.
- Handle the device carefully. Do not drop, bend or strike it. Otherwise the device may be damaged.
- Only qualified personnel can dismantle and repair the device.
- The humidity between 5% and 95% is recommended.

- Do not connect the charger while using the device for a long period. Failing to do so will trigger the protection mechanism of the battery, and the battery will not be charged. If you want to charge the battery, please reconnect the charger.
- Do not connect the charger while using the device for a long period or use the device and battery in non-operating temperature. Failing to do so will shorten battery life or cause battery swelling or leakage. If the battery shows signs of swelling or leakage, please stop use immediately.
- For pluggable equipment, the socket-outlet shall be installed near the equipment and shall be easily accessible.

## Battery Safety

### **WARNING!**

The battery is not removable. Removal may cause fire or explosion.

- Using ZTE-unapproved or incompatible battery, charger or power adapter may damage your device, shorten its lifespan or cause a fire, explosion or other hazards.

- The recommended operating temperatures are 0 °C to 35 °C and the storage temperatures are -20 °C to +45 °C. Extreme temperatures can damage the device and reduce the charging capacity and lifespan of your device and battery.
- Do not change or replace the built-in rechargeable battery in your device by yourself. The battery can only be changed or replaced by ZTE or ZTE authorized service provider.
- Do not place the device or the battery in or near heating equipment, such as microwave ovens, stoves or radiators. Keep the device and the battery away from excessive heat and direct sunlight. If not, the device or the battery may overheat and cause explosion or fire.
- Do not disassemble, squeeze or puncture the device, as this can cause explosion or fire.
- Do not throw the device into a fire to avoid explosion.
- Please disconnect the charger when the battery is fully charged. Overcharging may shorten the battery life.
- When not using the device for a long period, please charge the battery about half and then store the device in a cool dry place.
- If the battery damages or shows signs of swelling or leakage, please stop use immediately and contact ZTE or ZTE authorized service provider for replacement.



## Limited Warranty

This warranty does not apply to defects or errors in the product caused by:

- i. Reasonable abrasion.
- ii. End users' failure to follow ZTE's installation, operation or maintenance instructions or procedures.
- iii. End users' mishandling, misuse, negligence, or improper installation, disassembly, storage, servicing or operation of the product.
- iv. Modifications or repairs not provided by ZTE or a ZTE-certified individual.
- v. Power failures, surges, fire, flood, accidents, and actions of third parties or other events outside ZTE's reasonable control.
- vi. Usage of third-party products or usage in conjunction with third-party products if such defects are due to the combined usage.
- vii. Any other cause beyond the range of normal usage intended for the product.

End users have no right to reject or return the product, or receive a refund for the product from ZTE under the above-mentioned situations.

This warranty is end users' sole remedy and ZTE's sole liability for defective or nonconforming items, and is in lieu of all other warranties, expressed, implied or statutory, including but not limited to the implied warranties of merchantability and fitness for a particular purpose, unless otherwise required under the mandatory provisions of the law.

### **Limitation of Liability**

ZTE shall not be liable for any loss of profits or indirect, special, incidental or consequential damages resulting from or arising out of or in connection with using of this product, no matter whether or not ZTE had been advised, knew or should have known of the possibility of such damages, including, but not limited to lost profits, interruption of business, cost of capital, cost of substitute facilities or product, or any downtime cost.

## LEGAL INFORMATION

---

Copyright © 2020 ZTE CORPORATION.

All rights reserved.

No part of this publication may be excerpted, reproduced, translated or utilized in any form or by any means, electronic or mechanical, including photocopying and microfilm, without the prior written permission of ZTE Corporation.

The manual is published by ZTE Corporation. We reserve the right to make modifications on print errors or update specifications without prior notice.

**Version No.:** R1.0

## Troubleshooting

Problem	Recommended Action
The connection between your device and a PC through a USB cable cannot be established.	<ul style="list-style-type: none"><li data-bbox="357 269 916 400">• Install the software. Please run the installation program in the path of <b>My Computer &gt; ZTEMODEM</b>.</li><li data-bbox="357 407 916 575">• If the driver of your device is abnormal, reinstall the software. You need to uninstall the software first.</li></ul>
The connection between your device and a client through Wi-Fi cannot be established.	<ul style="list-style-type: none"><li data-bbox="357 604 916 684">• Ensure that the Wi-Fi function is enabled.</li><li data-bbox="357 691 916 771">• Refresh the network list and select the correct SSID.</li><li data-bbox="357 778 916 917">• Check the IP address, and ensure that your client can automatically obtain an IP address.</li><li data-bbox="357 924 916 1048">• Enter the correct network key (Wi-Fi password) when you connect the client to your device.</li></ul>

## Troubleshooting

---

Problem	Recommended Action
The client connected to the device cannot access the Internet.	<ul style="list-style-type: none"><li>• Ensure that your micro-SIM card is available.</li><li>• Change the location and find a place with good signal.</li><li>• Check the settings of the WAN connection mode.</li><li>• Contact your service provider and confirm your APN settings.</li></ul>
The 4G Mobile Hotspot configuration page cannot be visited.	<ul style="list-style-type: none"><li>• Enter the correct address. The default address is <a href="http://192.168.0.1">http://192.168.0.1</a> or <a href="http://ufi.ztedevice.com">http://ufi.ztedevice.com</a>.</li><li>• Use only one network adapter in your PC.</li><li>• Do not use any proxy server.</li></ul>

## Getting More Help

---

You can get help by:

- Sending an email to [mobile@zte.com.cn](mailto:mobile@zte.com.cn)
- Visiting [www.ztedevices.com](http://www.ztedevices.com)

## **Specific Absorption Rate (SAR)**

Your mobile device is a radio transmitter and receiver. It is designed not to exceed the limits for exposure to radio waves recommended by international guidelines. These guidelines were developed by the independent scientific organization ICNIRP and include safety margins designed to assure the protection of all persons, regardless of age and health.

The guidelines use a unit of measurement known as Specific Absorption Rate, or SAR. The SAR limit for mobile devices is 2 W/kg and the highest SAR value for this device when tested at the body was 1.37 W/kg\* with 5 mm distance.

As SAR is measured utilizing the device's highest transmitting power, the actual SAR of this device while operating is typically below that indicated above. This is due to automatic changes to the power level of the device to ensure it only uses the minimum power required to communicate with the network.

\* The tests are carried out in accordance with EN 50566, EN 62209-1, EN 62209-2, EN 62479 and EN 50663.

## Specification

This radio equipment operates with the following frequency bands and maximum radio-frequency power.

 **NOTE:**

All ZTE products are compliant with these power limits required by the European Union. Frequency bands supported by the product vary by model.

GSM 850/900: 32 dBm

GSM 1800/1900: 29 dBm

UMTS BAND 1/8: 22.5 dBm

LTE BAND 1/3: 22.5 dBm

LTE BAND 8/20: 23 dBm

LTE BAND 7/38: 22 dBm

802.11 b 2.4GHz Band: 16.5 dBm

802.11 g 2.4GHz Band: 15 dBm

802.11 n 2.4GHz Band: 14 dBm

## **CE Caution**

### **Battery Caution**

Risk of explosion if battery is replaced by an incorrect type.  
Dispose of used batteries according to the instructions.

### **USB Port**

This product shall only be connected to a USB interface of version USB 2.0.

### **Proper Use**

As described in this guide, your device can be used only in right location. If possible, please do not touch the antenna area on your device.



## Disposal of Your Old Appliance



1. When this crossed-out wheeled bin symbol is attached to a product, it means the product is covered by the European Directive 2012/19/EU.
2. All electrical and electronic products should be disposed of separately from the municipal waste stream via designated collection facilities appointed by the government or the local authorities.
3. The correct disposal of your old appliance will help prevent potential negative consequences for the environment and human health.

For this product's recycling information based on WEEE directive, please send an e-mail to [weee@zte.com.cn](mailto:weee@zte.com.cn)

## EU DECLARATION OF CONFORMITY



Hereby, ZTE Corporation declares that the radio equipment type ZTE MF920U is in compliance with Directive 2014/53/EU.

The full text of the EU declaration of conformity is available at the following Internet address:

<http://certification.ztedevices.com>



ZTE CORPORATION

NO. 55, Hi-tech Road South, Shenzhen, P.R.China

Postcode: 518057