

Electrical Characteristics	
Cable or Adaptor	RG58
Impedance	50 Ω
Frequency Range	DC - 6 GHz
V.S.W.R.	≦ 1.25
Working Voltage	≦ 1000 Vrms
Dielectric Withstanding Voltage	≦ 2500 Vrms

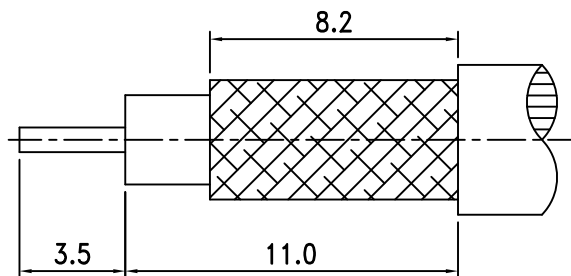

RECOMMENDED
CABLE STRIPPING DIM'S

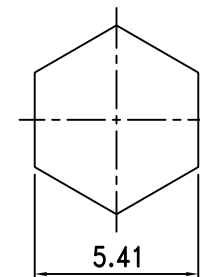

RECOMMENDED
CRIMPING TOOL SIZE

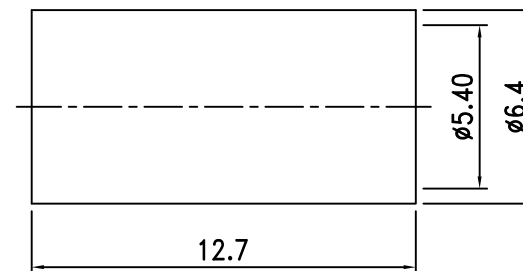
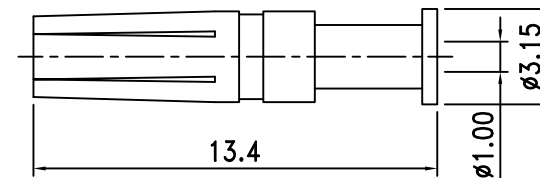
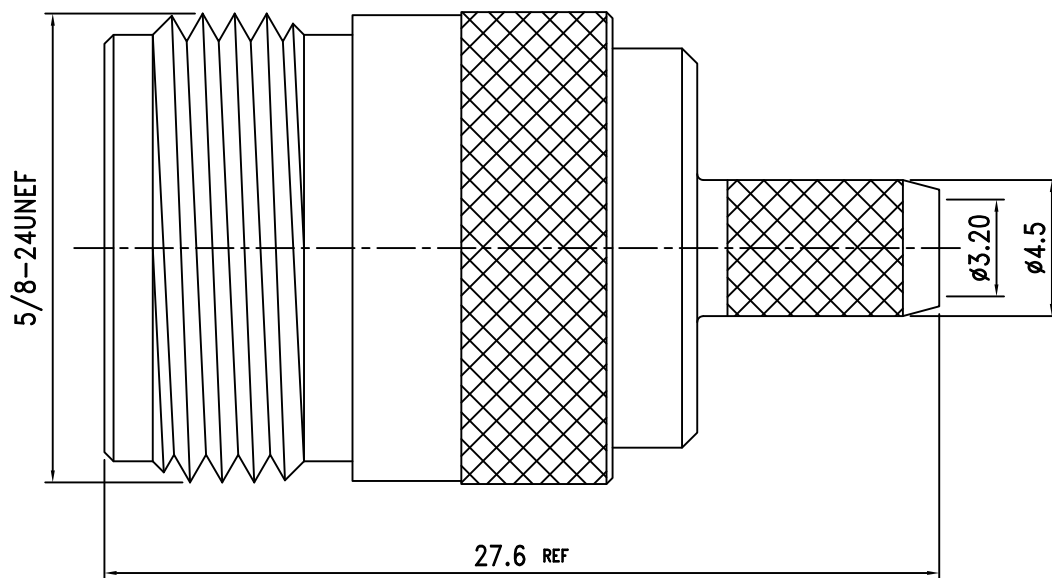

ROHS
COMPLIANT

7.				
6.				
5.	Ferrule	Brass	1	Nickel
4.	Insulation	PTFE	1	White
3.	Pin	Brass	1	Gold
2.	Barrel	Brass	1	Nickel
1.	Body	Brass	1	Nickel
NO.	DESCRIPTION	MATERIAL	Q' TY	FINISH

繪圖DRAWN	SCALE	UNITS
Kelly	比例 4:1	單位 mm
審核CHECKED	公差TOLERANCE	
Peter	.X	±0.2
主管APPROVAL	.XX	±0.1
	.XXX	±0.05
Peter	ANGLE	±0.5°

	夏尼有限公司 SHINING PRECISION CO., LTD	
圖名 TITLE	N-05F-2-TGN For Cable RG-58U	
版次REV.	電腦圖檔CAD FILE	日期DATE
A	C:/SHINING/N-PARTS/N-05F-2.DWG	2024.04.23