

Electrical Characteristics	
Cable or Adaptor	LMR240
Impedance	50 Ω
Frequency Range	DC - 6 GHz
V.S.W.R.	≦ 1.25
Working Voltage	≦ 1000 Vrms
Dielectric Withstanding Voltage	≦ 2500 Vrms

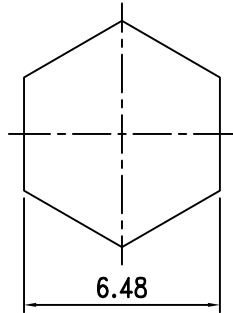

RECOMMENDED  
CRIMPING TOOL SIZE

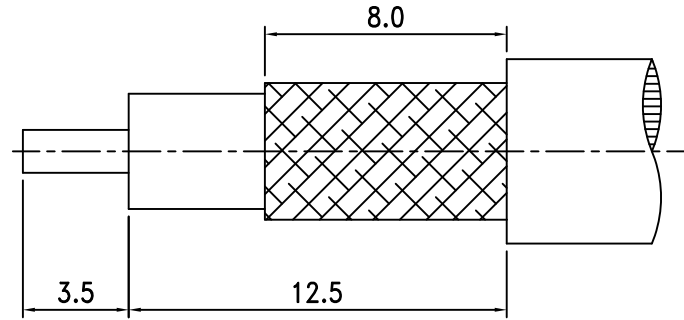

RECOMMENDED  
CABLE STRIPPING DIM'S

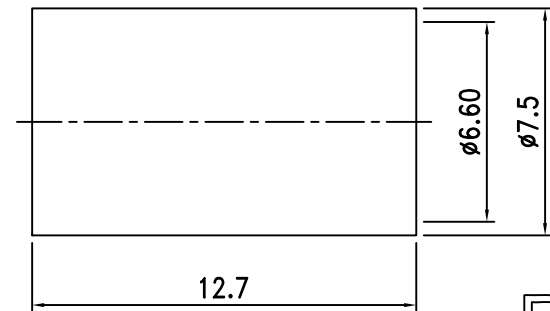
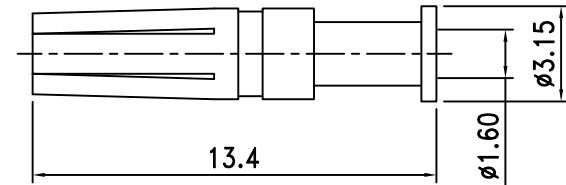
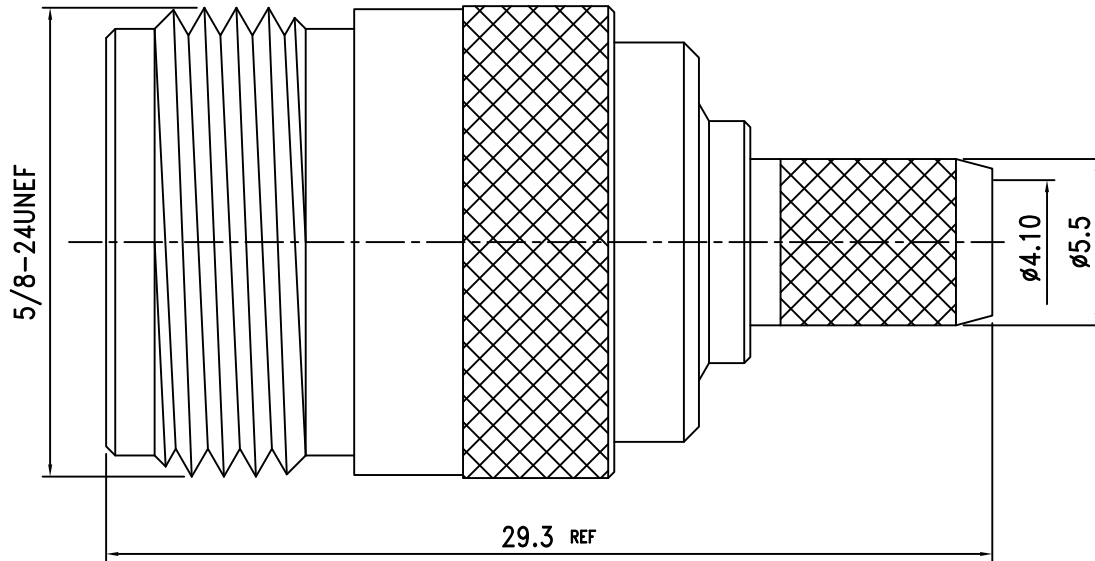

ROHS  
COMPLIANT

NO.	DESCRIPTION	MATERIAL	Q' TY	FINISH
5.	Ferrule	Brass	1	Nickel
4.	Barrel	Brass	1	Nickel
3.	Insulation	PTFE	1	White
2.	Pin	Brass	1	Gold
1.	Body	Brass	1	Nickel

繪圖DRAWN	SCALE	UNITS
Kelly	比例 4:1	單位 mm
審核CHECKED	公差TOLERANCE	
Peter	.X	±0.2
主管APPROVAL	.XX	±0.1
Peter	.XXX	±0.05
	ANGLE	±0.5°



夏尼有限公司  
SHINING PRECISION CO., LTD

圖名  
TITLE

N-05LM-3-TGN For Cable LMR-240

版次REV.

電腦圖檔CAD FILE

日期DATE

A

C:/SHINING/N-PARTS/N-05LM(Z)-3.DWG

2018.05.08