

Electrical Characteristics	
Cable or Adaptor	RG58
Impedance	50 Ω
Frequency Range	DC - 6 GHz
V.S.W.R.	≦ 1.25
Working Voltage	≦ 335 Vrms
Dielectric Withstanding Voltage	≦ 1000 Vrms

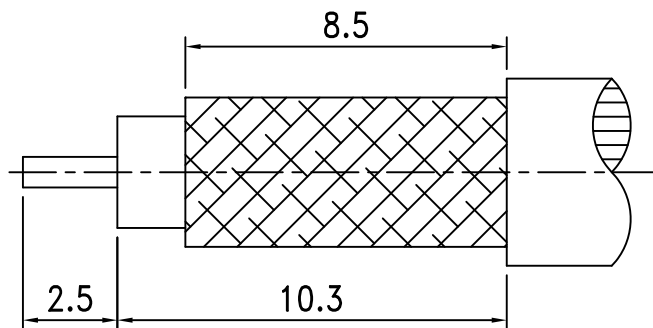

RECOMMENDED
CABLE STRIPPING DIM'S

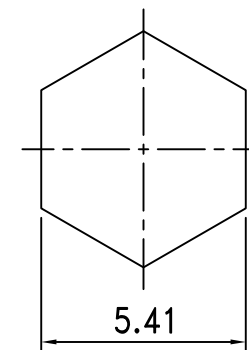

RECOMMENDED
CRIMPING TOOL SIZE

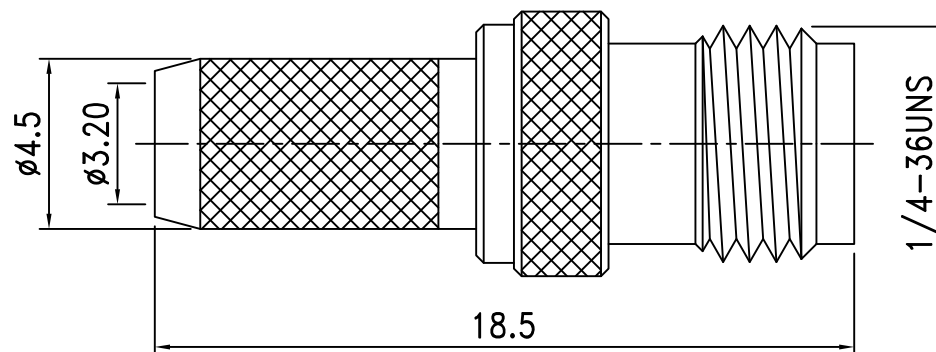
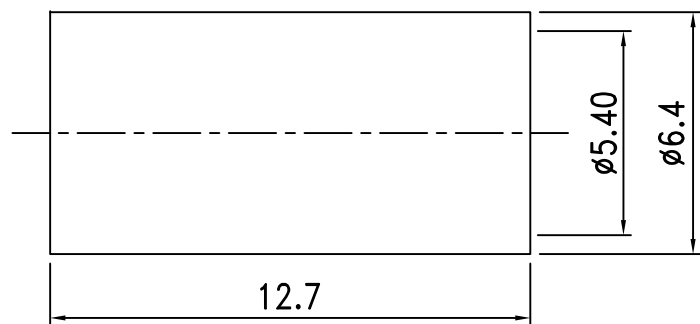
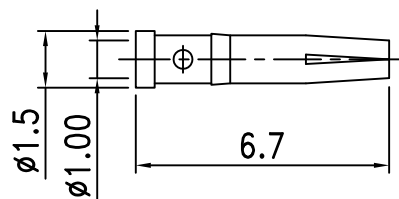

ROHS
COMPLIANT

NO.	DESCRIPTION	MATERIAL	Q' TY	FINISH
4.	Ferrule	Brass	1	Gold
3.	Insulation	PTFE	1	White
2.	Pin	Phosphor Bronze	1	Gold
1.	Body	Brass	1	Gold

繪圖DRAWN	SCALE	UNITS
Jack	比例 5:1	單位 mm
審核CHECKED	公差TOLERANCE	
<i>Peter</i>	.X	±0.2
主管APPROVAL	.XX	±0.1
	.XXX	±0.05
<i>Peter</i>	ANGLE	±0.5°

圖名 TITLE		夏尼有限公司 SHINING PRECISION CO., LTD	
版次REV.	電腦圖檔CAD FILE	日期DATE	
B	C:/SHINING/SMA-PARTS/SMA-03F.DWG	2015.07.31	