

Electrical Characteristics	
Cable or Adaptor	RG174 / RG316
Impedance	50 Ω
Frequency Range	DC - 6 GHz
V.S.W.R.	≦ 1.30
Working Voltage	≦ 250 Vrms
Dielectric Withstanding Voltage	≦ 750 Vrms

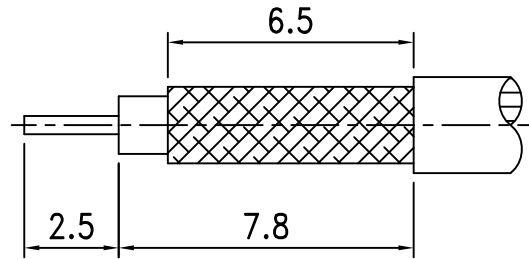

RECOMMENDED
CABLE STRIPPING DIM'S

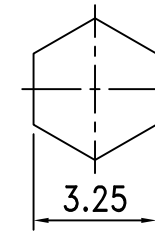

RECOMMENDED
CRIMPING TOOL SIZE

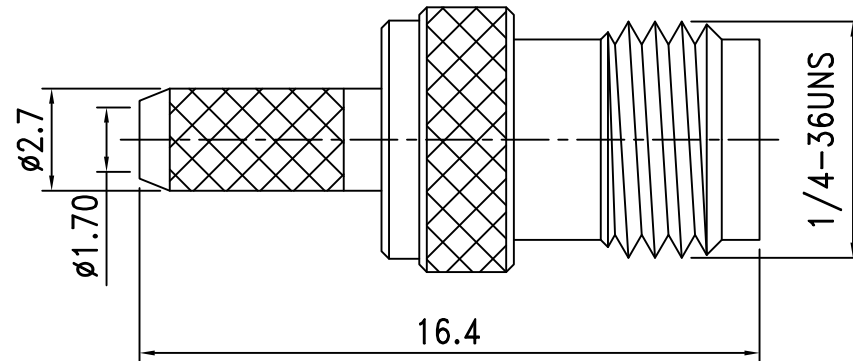
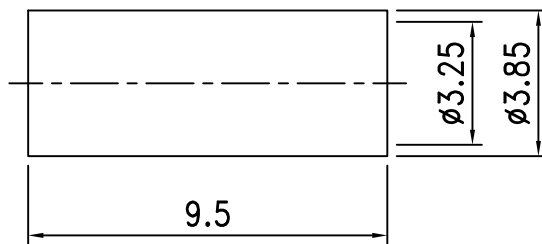
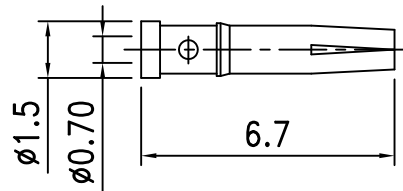

ROHS
COMPLIANT

NO.	DESCRIPTION	MATERIAL	Q' TY	FINISH
4.	Ferrule	Brass	1	Gold
3.	Insulation	PTFE	1	White
2.	Pin	Phosphor Bronze	1	Gold
1.	Body	Brass	1	Gold

繪圖DRAWN	SCALE	UNITS	夏尼有限公司 SHINING PRECISION CO., LTD	
Jenny	比例 5:1	單位 mm	圖名 TITLE SMA-03L-1-TGG For Cable RG-174U	
審核CHECKED	公差TOLERANCE			
Peter	.X	±0.2	版次REV.	電腦圖檔CAD FILE
主管APPROVAL	.XX	±0.1	A-1	C:/SHINING/SMA-FINISH/SMA-03L-1.DWG
Peter	.XXX	±0.05		日期DATE
	ANGLE	±0.5°		2017.03.07